

FAAC-INFO

TECHNICAL SERVICES DEPT.

Date: April 19, 2004	Vol. # 003
Subject: 750 Drive Unit	Reason For Info: Upgraded Units

Description:

The 750 Drive units have been updated. These updates include a new type of bearing, top seal system and piston heads that resemble that of the 760 and the bolts are now stainless steel.

This upgrade has taken place on units with the serial numbers starting from 01040000 and was done on both the 100° and the 180° units.

The following picture shows the new part numbers. Use the old part number for parts that do not have a number next to them.

See the attached drawing for part numbers.



750 Drive Unit



2171*

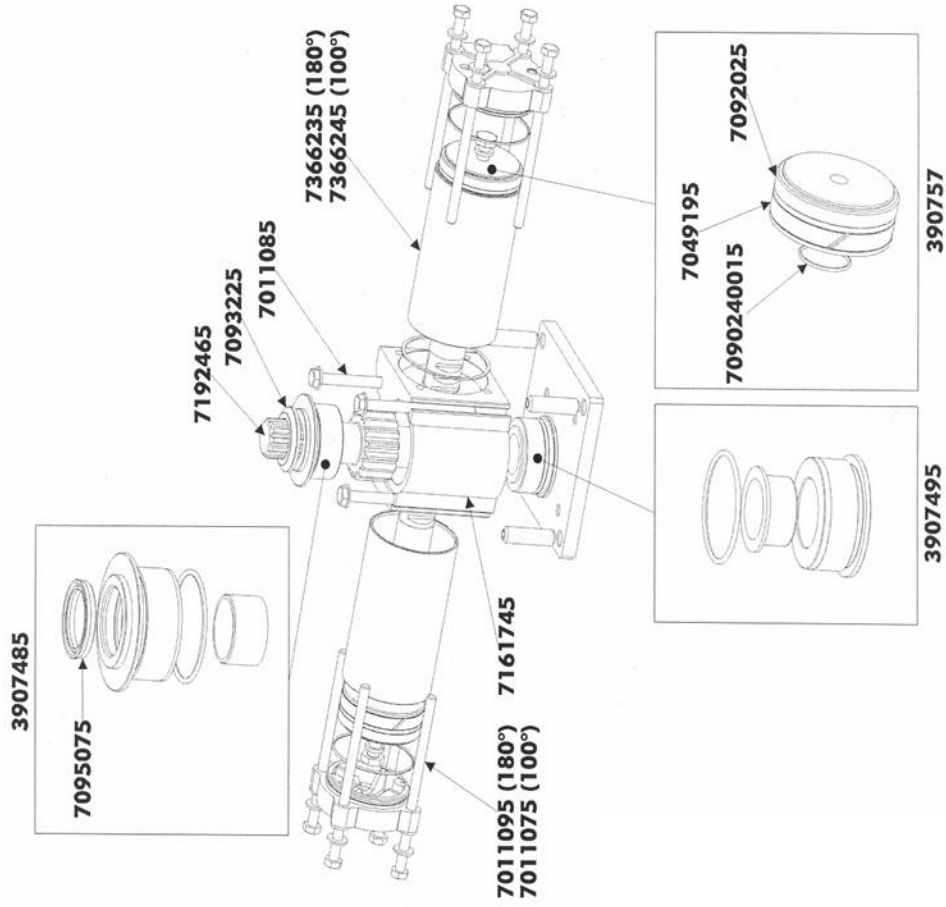

390635	Seal Kit (750 Drive)
3907485	Top Bushing Group
3907495	Bottom Bushing Group
7011075	Cylinder Bolts 100° = 8mm x 105mm (Stainless Bolt)
7011085	Body Bolts = 8mm x 100mm (Stainless Steel)
7011085	Cylinder Bolts 180° = 8mm x 140mm (Stainless Steel)
7083225	Top Gasket
7086075	Top Seal (Covered)
7161745	Body
7192465	Pinion Shaft
7366235	Cylinder 100° (Stainless Steel)
73662445	Cylinder 180° (Stainless Steel)
390757	Piston Assembly
7090240015	O-Ring (Rack to Piston)
7049195	O-Ring (Inner Piston Head)
7092025	O-Ring (Outer Piston Head)